

Full Paper

DEVELOPMENT OF A MACHINE FOR EXPRESSING VERNONIA AMYGDALINA LEAF JUICE

A.O. Oke

Department of Mechanical Engineering,
Faculty of Technology, Obafemi Awolowo University,
Ile-Ife, Nigeria.
tovinaoke@gmail.com

O.A. Koya

Department of Mechanical Engineering,
Faculty of Technology, Obafemi Awolowo University,
Ile-Ife, Nigeria.

C.T. Akanbi

Department of Food Science and Technology,
Faculty of Technology, Obafemi Awolowo University,
Ile-Ife, Nigeria.

ABSTRACT

Vernonia amygdalina leaf juice is known for its nutritive value and as food supplement. There is therefore, a need for a simple processing device for the leaf juice expression. This study developed a machine for producing contamination-free *V. amygdalina* leaf juice. The design of the machine was based on the principle of a pressure differential applied to the incoming leaf mash compared with that applied to the discharged material. Macerated leaves were compressed through a tapered screw conveyor; whose shaft terminates as a rising but short conical kink. The maximum juice yield of 41.39% was expressed from the leaf mash at pressing pressure and residence time of 6.09 MPa and 11 min, respectively. The throughput of the machine was 9.60 kg/h and the juice extraction rate was 1.86 /h at leaf to water ratio of 1: 0.8. The maximum juice expression efficiency was 15.54% at 1:1.2 leaf to water ratio, 60 rpm constant rotational motor speed and 11.99 kg/h feeding rate. Approximately 26.38% of the inherent moisture content of the leaf was expressed by the machine. It is expected that the machine may be used to express juice from other plant leaves having comparative physical properties. The machine therefore provides a viable technique for mechanical expression of good quality *V. amygdalina* leaf juice.

Keywords: *Vernonia amygdalina* leaf juice, machine throughput, bioactive substances.

1. INTRODUCTION

Vernonia amygdalina (bitter leaf) has been noted for its high nutritional qualities being a good source of its crude protein and different kinds of minerals like phosphorus, calcium, sulfur, magnesium. The juice is, therefore used as a supplement in health food products; in particular, its concentrate which is high in protein (Tangka, 2003). It is also prescribed in the treatment of malaria fever, amoebic dysentery, several other intestinal parasites and stomach-aches (Huffman, 2003). The proximate analysis of the leaf as reported

by Tangka and Penda (2007) consist of (dry weight basis): moisture content (13.12%); fat (12.29%); protein (16.34%); crude fibre (3.40%); ash (0.63%) and total resins (18.75).

Traditionally, the bitter leaves are macerated with mortar and pestle. After this step, the macerated leaves are kept inside a cloth and squeezed with hand. The practice is tedious, time-consuming and sometimes unhygienic. Juice from vegetable leaves has been expressed by different methods. Such are planetary mill and grinding machine, which significantly accelerate the process of mass transfer. In some other devices, pulsation, vibration, electric pulses, and other factors were also used to intensify the production of the juice (Ivanov *et al.*, 2004). However, these techniques were used without considering the structure and the strength of the plant parts such as the root, the bark, the stem, the leaf and the flower. Consequently, the juice expressed was turbid most importantly while processing plant leaf and flowers. Furthermore, it had been noted that when the mechanical strength of the individual types of raw material is not taken into consideration, the machine parts wear rapidly and break down (Kreshchenyuk *et al.*, 1971). It is therefore necessary to select the optimal process conditions of the specific plant material and, consequently, the most appropriate method of juice expression; hence, the main objective of the research was to develop a machine for the expression of *V. amygdalina* leaf juice.

2. MATERIALS AND METHODS

2.1. Sample Collection and Preparation

Fully expanded and freshly harvested *Vernonia amygdalina* leaves were collected for the experiment from the Teaching and Research Farm of Obafemi Awolowo University, Ile-Ife, during the dry season, in the month of February. Approximately 500 g of fresh *V. amygdalina* leaves were obtained. The leaves were sorted, cleaned, and comminuted manually to obtain a homogenous mash. The mash was kept in a sealed polythene bag to prevent evaporation prior to use. The initial moisture content (%wb), of the leaf mash was determined according to standard S358.2 (ASAE, 2001) as:

$$MC = \frac{M_L}{M_S} \times 100 \% \quad (1)$$

Where: MC (%) is moisture content, M_L is mass of moisture loss (g) and M_S is mass of leaf sample (g).

2.2. Determination of Optimal Processing Conditions for Juice Expression

A measure of 50 g leaf mash sample was weighed. The weighed sample was transferred to the pressing rig shown in Fig.1, where the juice was expressed. The mash sample was wrapped inside a cheese cloth which was placed inside the pressing cylinder, and the compression load was increased gradually with the use of a hydraulic jack. The quantities of juice expressed were weighed at intervals of 2 min until there was noticeable flow of the expressed juice. Pressing

pressures at different values of 4, 5, and 6 MPa; pressing time of 10 min at 2 min interval, and the pressed leaf mash initial and final moisture content were determined against the juice yield and the compression ratio. The juice yield J_Y , in percentage of leaf mash, was calculated using equation 2:

$$J_Y = \frac{100M_j}{M_s} \% \quad (2)$$

Where: M_j is the mass of juice expressed in g, M_s is the mass of leaf mash sample in g.

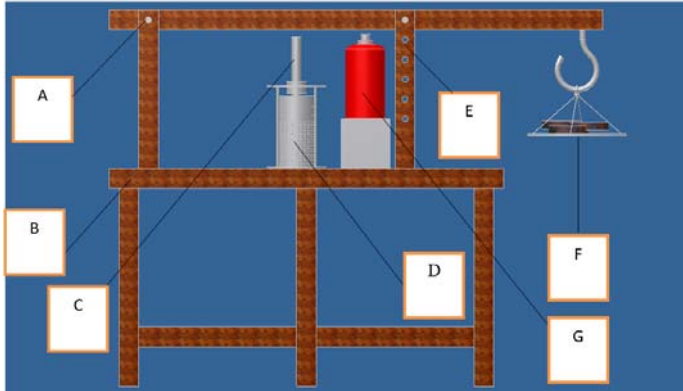

Fig. 1: Schematic diagram of the laboratory pressing rig.

A – Fulcrum, B – Table, C – Piston, D – Perforated cylinder enclosed, E – Support, F – Loading point, and G – Hydraulic press

The compression ratio (C. R) is defined by Equation. 3. It was used as an indication for the rate of pressing.

$$C. R = \frac{h_1}{h_2} \quad (3)$$

Where, h_1 and h_2 are respectively the initial and the final height of pressed mash sample in mm.

2.3. The Experimental Juice Machine

The principle of a pressure differential applied to the incoming leaf mash versus that applied to the discharge material is the working mechanism for the machine. The compression ratio is one of the most important criteria influencing the performance of a screw press. It was defined as the ratio of volume of material displaced per revolution of the shaft at the feed section to the volume displaced at the discharge section.

2.3.1. Design Considerations

The development of the experimental machine was based on information available and data from the compression experiment through the laboratory pressing rig. The machine was designed to:

- i. effectively compress the juice through the tapered shaft at the discharge end; and
- ii. have minimal damage on the expressed juice chemical content without contamination of the juice expressed.

The experimental machine was considered to be simple in design and easy to fabricate, and its operation does not require any previous technical training.

2.3.2. Forces Acting on the Screw Thread

The two main forces acting on the screw thread are the compression force required to convey and press the leaves, and the

frictional force resulting from the screw motion. The worm shaft is subjected to pressure due to the compression of leaves. This pressure increases from a minimum value at the feed end to a maximum value at the discharge end. Fig. 2 shows the elemental load, L acting on the unit length of the thread. The load, L acts normal to the threaded surface along line XO . The axial and radial forces are resolved, such that:

$$F_t = (P_{max} \times A_{cs}) \mu + F_c \quad (4)$$

where, F_t is the resultant tangential force in N; μ is coefficient of static friction; P_{max} is the maximum pressure required for expression of leaf mash in MPa; A_{cs} is the curved surface area of the pressing zone in m^2 ; F_c is the compression force due to the maximum pressure for expression of juice from leaf mash in N.

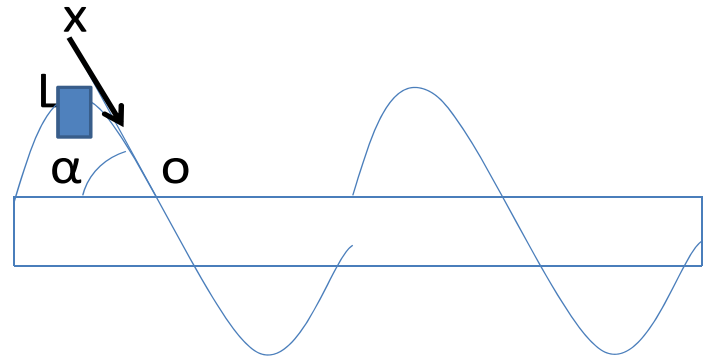

Fig. 2: Schematic diagram of tangential force acting on the conveyor flight screw.

2.3.3. Machine Components Design

The machine was designed according to engineering design standards. The details of the machine components are shown in Appendix A. The Specification of major components of the experimental juice machine is shown in Table 1.

Table 1 Specification of major components of the experimental juice machine

S/N	Component	Specification	Material
01	Screw shaft diameter	25.00 mm	Stainless steel
02	Kink diameter	52.00 mm	Stainless steel
03	Barrel diameters:		
	Feed point	140.00 mm	Stainless steel
	discharge point	60.00 mm	
04	Screw pitch	40.00 mm	Stainless steel
05	Screw length per turn	80.00 mm	Stainless steel
06	Power rating of electric motor	1.5 kW	composite

2.4. Assembly of the Experimental Juice Machine

The experimental machine (Fig. 3) consists of the following parts: a tapered barrel having a screw conveyor; a shaft on which is welded the screw (or helix), a hopper surmounted on the barrel. The tapered barrel, made of stainless steel, had 140 mm inside diameter at feed point and 60 mm at discharge point. It had a length of 400 mm and a screen of full length. It was through this screen that the juice was pressed into a basin by the juice outlet. The shaft was made of stainless steel. It had a diameter of 25.0 mm, while the adjustable cone was bolted to the end part. The two ends of the shaft were in thrust bearings and one end carried the pulley through which power was transmitted by a V-belt from an electric motor. The screw flight was made of stainless steel sheet of 25 mm inner diameter, 60 mm outer diameter and 1.5 mm thickness, wound and welded to the shaft in the

clockwise direction. The constant pitch of the screw was 40 mm. The hopper was made of stainless steel sheet of 1.5 mm thickness. The macerated leaf mash was introduced into the compression barrel through the hopper. The frame was constructed from 50 x 50 mm angle iron. The overall dimensions of the machine were 1500 mm high, 200 mm wide and 700 mm long. A 1.5 kW gear reduction motor rotating at 90 rpm was used to supply the required power to rotate the screw shaft. A pulley of diameter 45 mm was used to further reduce the speed to 60 rpm. The parts' list is shown on Table 2. The orthographic views of the machine are shown on Fig. 4.

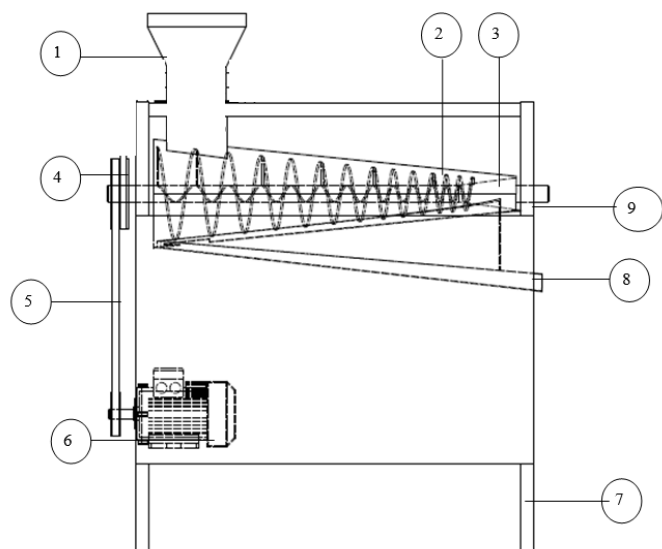

Fig. 3: The experimental machine components. (1) Hopper, (2) compression barrel, (3) kink, (4) pulley, (5) belt, (6) electric motor, (7) frame, (8) juice chute, (9) leaf mash chute.

2.5. Performance Evaluation of the Machine

Fresh *Vernonia amygdalina* leaves were obtained, sorted and macerated to 5 mm broad-bands leaf mash. The machine was set into operation and 200 g of the leaf mash was mixed with measured quantity of water and then introduced into the machine through the hopper. In the pressing barrel, the screw shaft conveyed, pressed the leaf mash to express the juice. Both the juice extracted and the pressed leaf mash were collected and weighed separately. From the values obtained, juice yield, expression efficiency and machine throughput were computed. Mathematically, juice yield, J_Y , expression efficiency, J_E and machine throughput, M_T were expressed (Oyeleke and Olaniyan, 2007; Arlabosse *et al.*, 2011) as:

$$J_Y = \frac{100W_J}{W_S} \% \quad (5)$$

$$J_E = \frac{100W_J C_J}{W_S C_S} \% \quad (6)$$

Table 2: parts List of the Machine

ITEM	QTY	PART	MATERIAL
1	1	Hopper	Stainless Steel
2	1	Tapered Barrel	Stainless steel
3	1	V-Belt	Rubber
4	1	Frame	Mild Steel
5	2	Pulley	Mild Steel
6	1	Juice Chute	Stainless Steel
7	1	Electric Motor	Composite
8	2	Side Cover	Mild Steel

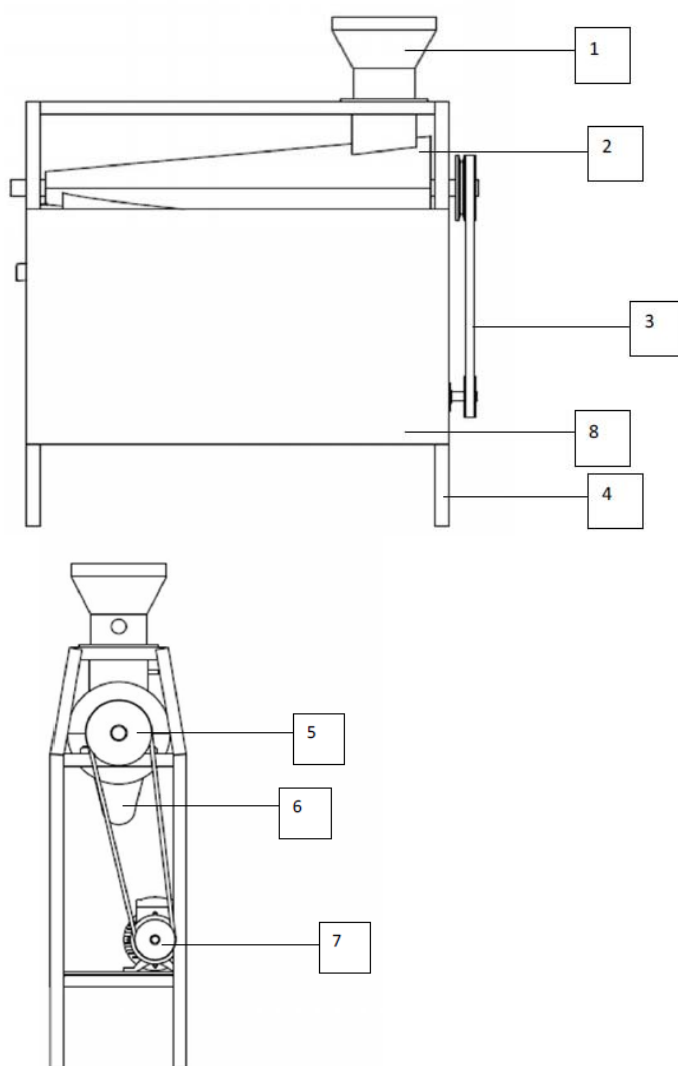

Fig. 4: Orthographic views of the experimental machine

$$M_T = \frac{W_S}{T_P} \text{ kg/h} \quad (7)$$

where, W_J is the mass of the juice expressed in g, W_S is the mass of leaf mash sample in g, W_J is the mass of leaf juice expressed in g, C_J is the flavonoid content of the juice yield in %, C_S is the flavonoid content of the leaf sample in %, and T_P is processing time in h.

2.6. Proximate Analysis of the Expressed Juice

The physical and chemical properties tests were carried out on the expressed juice, to determine of the chemical constituents of the expressed juice. The properties consist of the dry solid content, protein content, ash content, ether extract and the pH level of the juice using standard methods. The contents were determined from juice and pressed mash according to standards (ASAE, 2001; AOAC, 2004).

3. RESULTS AND DISCUSSION

3.1. Results of preliminary tests

The experiments on the *V. amygdalina* leaf mash revealed the effects of pressing pressure; residence time and their relationship on the juice yield. The summary of the data is shown in Table 3 and the results are discussed below.

3.2. Effect of pressing pressure on the juice yield

The effect of pressing pressure on the juice yield at different residence times is shown on Fig. 5. Increase of the pressing pressure progressively increases the juice yield exponentially at each residence time. Similar trends had been reported by previous researchers on juice expression (Sharif *et al.*, 1993; Sinha *et al.*, 2000). The relationship between the juice yield and the pressing pressure at 10 min residence time was determined using regression analysis as presented in Equation 7.

$$J_y = -2.475P^2 + 30.135P - 50.34 \quad (R^2 = 0.999) \quad (7)$$

Where, J_y is the juice yield in % and P is pressing pressure in MPa. The maximum pressing pressure and the juice yield were obtained as 6.09 MPa and 41.39% respectively. The maximum pressing pressure is significant in determining the power required for an appropriate plant leaf juice expressing machine.

Fig. 6 shows the relationship between the pressing pressure and the moisture content of the plant leaf mash. From the graph, a power transformed regression analysis equation was developed, as presented in Equation 8.

$$MC = 82.629P^{-0.076} \quad (R^2 = 0.852) \quad (8)$$

where, P is applied pressure (MPa), and MC is final moisture content (%w.b).

Sinha *et al.* (2000) developed a similar expression relating the final moisture content of pressed alfalfa mash to the applied pressure in the form $MC = 68.4P^{-0.0442}$. The predicted moisture content was lower than the pressed pulp in the present study, implying that the correlation is material specific. This might be due to the difference in the textural resistance and the initial moisture contents of alfalfa leaf and *Vernonia amygdalina* leaf. Pressure at 6.09 MPa reduced the moisture content of the plant leaf mash from 80.48 to 72.03%. This indicates the minimum moisture content at which additional pressing pressure will not increase yield significantly. Approximately 52% of the total moisture content was removed. In order to further reduce the moisture content or improve on the juice yield, tissue softening additional methods may be employed, such as, pulse electric field-assisted press (Lebovka *et al.*, 2003); thermally assisted mechanical dewatering (TAMD) (Praporscic *et al.*, 2006; Kerfai *et al.*, 2011).

Table 3: Design related properties of *Vernonia amygdalina* leaf mash

Properties	Sample size N	Mean Value
Angle of repose (degree)	3	48.33(±2.89)
Coefficient of friction (stainless steel)	3	1.12(±0.3)
Bulk density of leaf mash (kg/m ³)	3	111.22 (±0.0011)
Moisture content (% w.b)	3	80.48 (±0.53)
Compression ratio at maximum Pressure, 6.09 MPa	3	6.73 (±0.44)
Leaf juice density (kg/m ³)	3	1090 (5.03)

*Data in parenthesis are the standard deviations

3.3. Effect of residence time on the juice yield

The juice yield at the different pressing pressures with respect to pressing time is shown in Fig. 7. At each pressing pressure, there is a progressive increase in the juice yield. The juice yield gradually reduces with time as the pressure increases above 5 MPa. This is explained by the fact that the plant leaf mash is initially compressed rapidly; as its thickness increases, the juice released also reduces. The juice flows out almost immediately; about 85% of the juice is recovered after 8 min. Pirie (1987) reported a similar result during his research on an economical unit for pressing juice from fibrous pulps.

From Equation 9, the residence time at the maximum juice yield corresponding to 6.09 MPa was approximately determined as 11 min.

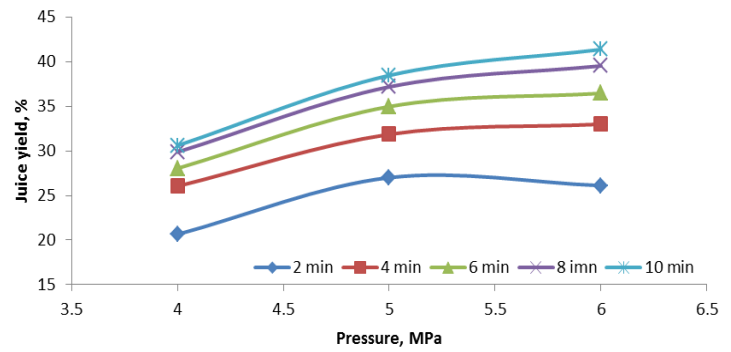

Fig. 5: Effect of pressing pressure on juice yield at different residence times.

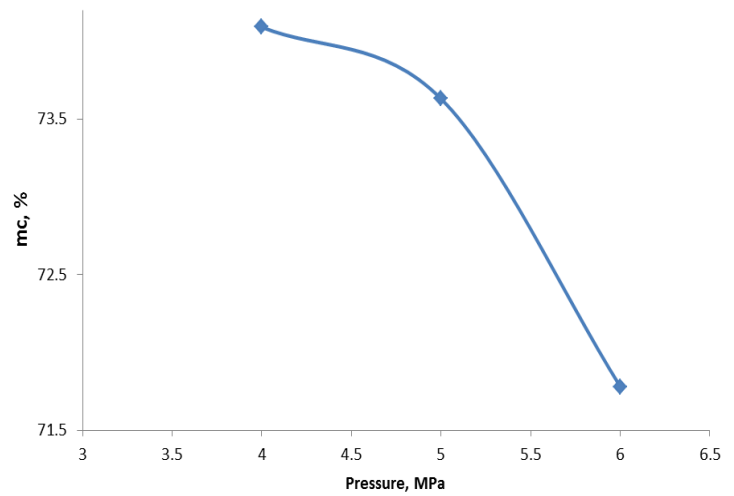

Fig. 6: Effect of pressure on moisture content for 10 mins residence time.

$$J_y = -0.1868X^2 + 4.0944X + 18.942 \quad (R^2 = 0.995) \quad (9)$$

where, J_y is the juice yield in percentage and X is the residence time in minutes

The data provided are primary data for the design of the leaf juice expressing machine.

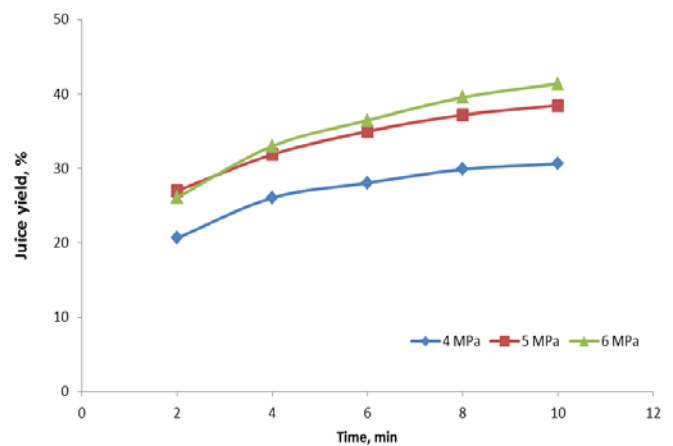

Fig. 7: Effect of residence time on juice yield at different pressing pressures.

3.4. Effect of Water Addition on the Expression Efficiency of the Machine

The pictures of the experimental juice machine, the leaf juice expressed; the leaf mash before and after expression are shown on Plates 1, 2, 3 and 4 respectively. Fig. 8 shows the juice yield and expression efficiency of the machine at the different leaf to water ratios. As the quantity of water increases, the efficiency also increases. At the ratio of 1:1.2, the highest efficiency of 15.54% was attained; while, the least efficiency of 3.67% was recorded at 1:0.8. Generally, the results give a low performance of the machine at all ratios. This may due to the low compression ratio of the machine. The need to attain the optimum contrition at the discharge has been a major limitation of screw presses (Singh and Bargale 2000). However, it is shown that the preliminary wetting of the mash enhances the process of expression in the experimental machine. Ivanov *et al.* (2004) had reported similar trend in the study of medicinal plant material extraction using a planetary mill.

The machine throughput has the maximum values of 9.6 kg/h at leaf to water ratio of 1: 1.1.2 (Table 3); so that the juice extraction rate was 1.83 kg/h or 1.68 l/h.



Plate 1. The experimental juice extracting machine



Plate 3. The leaf mash before expression

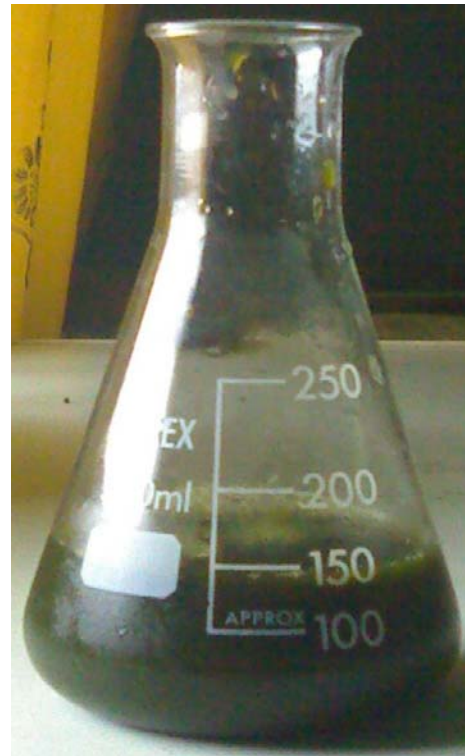

Plate 2. The expressed leaf juice



Plate 4. The leaf mash after expression

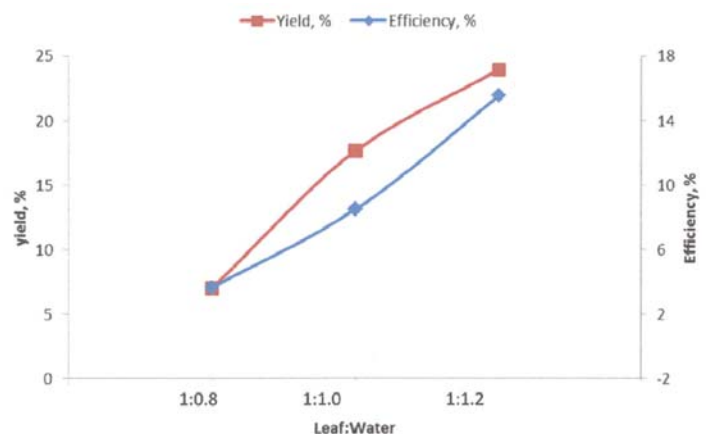

Fig. 8: Effect of water addition on Juice expression efficiency and juice yield.

3.5. Some Physico-Chemical Properties of Fresh Leaf and the Expressed Juice

Some physico-chemical properties (dry solid matter, ash content, ether extract and protein content) of the fresh leaf and the juice yield are shown in Table 4. At leaf to water ratio 1:0.8, the chemical constituents were at maximum: dry solid was 2.83%, protein was 23.63% and ash was 0.79%. Also, at 1:1.2, the minimum values were recorded: dry solid was 1.33%, protein was 19.03%, and ash was 0.26%. The ether extract was highest, 0.047% at leaf to water ratio 1:1.0 and lowest, 0.01% at 1:0.8. The difference in the values shows the effect of water addition on the juice yield. At leaf to water ratio of 1:1.2, the chemical constituents (dry solid, protein and ash content) decreased with an increase in the water addition. Ogblechi (2006) had reported a similar result in the expression of date palm fruit juice. Furthermore, the quality of the juice was unaffected by the expression process since the chemical constituents of the expressed juice varied moderately when compared with the fresh leaf. Also, the proximate analysis of the juice using the compression test rig (i.e. no water addition) gave higher values than the juice from the machine except the protein content (15.97%) which was the lowest. This may be due to chemical reaction that increased the quantity of protein in the juice from the machine (i.e. with water addition). Aregbesola *et al.* (2009) also identified a similar occurrence in their study of production of herbal tea from *Hibiscus sabdariffa* calyces.

Table 4: Effect of Water addition on the Machine Throughput*

S/n	Quantity of leaf, g	Quantity of water, g	Time taken, s	Juice yield, g	Extraction rate, kg/h	Machine Throughput, kg/h
1	160	128	71	19.32(1.17)**	0.98	8.11
2	200	160	80	31.99(5.08)	1.44	9.00
3	240	192	90	45.65(12.54)	1.83	9.60

*Values determined at 1:0.8 (Leaf to water ratio). **Number in parentheses are standard deviations.

Table 5: Proximate Analysis of fresh leaf and the juice expressed.

Sample Leaf:Water	Juice yield (%)	Solid Matter (%)	Moisture (%) (w. b.)	Ash, %	Crude protein (%)	Ether extract (%)	P _H
Fresh leaf	-	20.16	79.84	1.6**	25.66**	0.25**	-
No water*	41.37	7.51	92.49	1.88	15.97	0.150	4.9
1:0.8	7.02	2.83	97.17	0.79	23.63	0.010	6.7
1:1.0	17.63	1.61	98.39	0.34	22.53	0.047	5.4
1:1.2	23.95	1.33	98.67	0.26	19.03	0.033	4.7

*Data in the row was carried out using the laboratory press. **Source: Tangka and Penda (2007)

4. CONCLUSIONS

A simple machine for the expression of leaf juice has been developed for *Vernonia amygdalina* leaf. The results from the compression experiment showed that the maximum pressing pressure and the juice yield were 6.09 MPa and 41.39% at 10 min residence time. The machine gave maximum juice yield of 1.86 l/h and throughput of 9.6 kg/h at leaf to water ratio of 1:1.2. The maximum juice expression efficiency was 15.54% at 200 g sample leaf mash, 60 rpm motor speed and 11.99 kg/h feeding rate. The juice expression efficiency increased (3.67–15.54%) with leaf to water ratio (1:0.8 – 1:1.2). Approximately 26.38% of the inherent moisture content of the leaf was expressed by the machine. The proximate analysis results show that preliminary wetting of the mash intensifies the process of juice expression using the experimental machine. It is expected that the machine may be used to express juice from other plant leaves having comparative physical properties.

ACKNOWLEDGMENT

The authors are grateful to Mr. Kayode Ogunyemi of Department of Animal Science, the technical staff of Mechanical and Agricultural Engineering, Obafemi Awolowo University, Ile-Ife, for their technical supports in the course of this work.

Notations

A_{cs}	Curved surface area of the pressing zone, m ²
C_J	Flavonoid content of the juice yield, %
C. R.	Compression Ratio
C_s	Initial flavonoid content of the leaf sample, %
F_c	Compression force due to the maximum pressure for expression of leaf mash, N
F_t	Tangential force, N
h_1	Initial height of pressed mash sample, mm
h_2	Final height of pressed mash sample, mm
J_E	Juice expression efficiency, %
J_Y	Juice yield, g
M_C	Machine throughput, kg/h
MC	Moisture content of sample, % (w.b)
P_{max}	Maximum pressure required for expression of leaf mash, MPa
T_P	Time of processing, h
W_L	Mass of moisture loss, g
W_J	Mass of leaf juice expressed, g
W_S	Mass of leaf mash sample, g;
μ	Coefficient of static friction

REFERENCES

- AOAC. Official methods of analysis. Association of Official Analytical Chemists, Washington, D. C. 54 –57, 2004.
- Aregbesola, O. A., Faboro, M. O. and Hounkanrin, B.A. Studies on the production of herbal tea from *Hibiscus sabdariffa* (Roselle) calyces. 3rd Proceedings of Nigerian Institute of Agricultural Engineering, 210–213, 2009.
- Arlabosse, P., Blanca, M., Kerfaic, S. and Fernandez, A. Production of green juice with an intensive thermo-mechanical fraction process. Part I: effect of processing conditions on the dewatering kinetics. *Chemical Engineering Journal* 168: 586–592, 2011.
- ASAE Standards. Moisture measurement–forages, 47th edition. American Society of Agricultural Engineers, ASAE S358.2, St. Joseph, Michigan. 57–59, 2001.
- Huffman, M. A. Animal self-medication and ethno-medicine: exploitation and exploration of medicinal properties of plants. *Proceedings of the Nutrition Society*, 62: 371–381, 2003.
- Ivanov, E. V., Shvyrev M. V., Minina S. A., and Kochnev V. G. Method of medicinal plant material extraction in a planetary mill. *Pharmaceutical Chemistry Journal*. 38 (11): 29–32, 2004.
- Kerfaic S., Fernandez A., Mathe S., Alfenore S., Arlabosse P. Production of green juice with an intensive thermo-mechanical fraction process. Part II: effect of processing conditions on the liquid fraction properties. *Chemical Engineering Journal* 167: 132-139, 2011.
- Kreshchenyuk, S. I., Litvinenko V. I. and Prokopenko A. P. Machines for grinding medicinal plant raw material. *Khar'kov Scientific-Research Institute of Pharmaceutical Chemistry*, 5 (6): 46–48, 1971.
- Lebovka, N. I., Bazhal, M. I., and Vorobiev, E. Enhanced expression of juice from soft vegetable tissues by pulsed electric fields: consolidation stages analysis. *Journal of Food Engineering* 59: 309–317, 2003.
- Ogblechi, S.R. Development of a Mechanical Extractor for Date Fruit Juice Processing. Unpublished M.Sc. thesis, Department of Agricultural Engineering, Obafemi Awolowo University, Ile-Ife. 72–75, 2006.
- Oke, A. O. Development of a Machine for Expressing *Vernonia amygdalina* Leaf Juice. M. Sc. Thesis, Department of Mechanical Engineering, Obafemi Awolowo University, Ile-Ife, Nigeria, 2012.

Okoye, C. N., Jiang, J., Hui, L. Y. Design and development of secondary controlled industrial palm kernel nut vegetable oil expeller plant for energy saving and recuperation. *Journal of Food Engineering*, 87: 578–590, 2008.

Oyeleke, F.I. and Olaniyan, A. M. Extraction of juice from tropical fruits using a small scale multi-fruit juice extractor. *African Crop Science Conference Proceedings*. 8: 1803–1808, 2007.

Pirie N. W. An economical unit for pressing juice from fibrous pulps. *Journal of Agricultural Engineering Research*. 38: 217–222, 1987.

Sharif, H. I., Al-Mashat, and Carlos, A. Z. Stress relaxation behavior of apple pomace and effect of temperature, pressing aid and compaction rate on juice yield. *Journal of Food Engineering*. 20:247–266, 1993.

Singh, J. and Bargale P. C. Development of a small capacity double stage compression screw press for oil expression. *Journal of Food Engineering*. 43: 75–82, 2000.

Sinha, S., Sokhansanj, S., Crerar, W. J., Yang, W., Tabil, L. G., Khoshtaghaza, M. H. and Patil, R.T. Mechanical dewatering of chopped alfalfa using an experimental piston-cylinder assembly. *Canadian Agricultural Engineering* 42 (3): 153–156, 2000.

Tangka, J. K. Analysis of the thermal energy requirements for the extraction of leaf protein concentrate from some green plants. *Biosystems Engineering*, 86 (4): 473–479, 2003.

Tangka, J. K. and Penda, P.M. Development and performance evaluation of a medium-scale system for processing bitter leaf. *Biosystems Engineering*, 96 (2): 223–229, 2007.

APPENDIX A: DESIGN OF THE MACHINE COMPONENTS

Determination of compression ratio

Compression experiment was carried out to determine the theoretical compression ratio (C. R) of the leaf mash at maximum pressing pressure. The design compression ratio is thus calculated:

$$C.R = \frac{D_1^2 - d^2}{D_2^2 - D^2}$$

(A1) where D_1 is barrel diameter at feed point, D_2 is Barrel diameter at discharge point, D is the kink diameter, and d is the shaft diameter. Given: d is 25 mm, D is 52 mm, D_1 is 82 mm and then D_2 is 60 mm. The shaft at the discharge end was made conical to increase the compression of the juice from the leaf mash.

Determination of theoretical screw volume

The theoretical screw volume is given by

$$V_s = \text{screw area} \times \text{pitch}$$

$$V_s = \frac{\pi(D_1^2 - d^2)P}{4} \tag{A2}$$

where, D_1 is the barrel diameter at feed, d is the shaft diameter, P is the pitch
Substituting into the formula

$$V_s = \frac{\pi(0.082^2 - 0.025^2)0.004}{4}$$

$$= 1.92 \times 10^{-5} \text{ m}^3$$

Determination of mass flow rate

Mass flowrate is dependent on bulk density, theoretical screw volume, speed of screw and filling factor.

$$\dot{m} = V_s N \rho \phi \tag{A3}$$

where, V_s is Screw volume, N is speed of rotation, ρ is leaf mash bulk density, kg/m^3 , ϕ is filling factor, 45 % (Altamuro, 1996).

$$= 1.92 \times 10^{-5} \times 6.284 \times 111.22 \times 0.45$$

$$= 0.00604 \text{ kg/s}$$

$$= 21.74 \text{ kg/h}$$

The power requirement

The input power during expression of plant materials depends on the rate of energy consumption within the limits of the transport and pressing zones. The highest power consumption is required in the pressing zone, where the highest pressures arise in the material to be expressed. From the experimental results, a maximum pressure 16 MPa is required at the pressing zone. Varying the shaft speed with the expressing pressure, the optimal power required was generated (Oke, 2012). A power source of 1.0 kW at a speed of not more than 60 rpm was determined. For this work, a 1.5 kW reduction gear motor was used.

The Barrel

The barrel was a tapered pipe, made of stainless steel. The barrel was designed on the basis of the required internal pressure for the juice expression. Using the standard stress analysis techniques applied to thin wall pressure vessels (Khurmi and Gupta, 2010), the tangential stress, σ , perpendicular to the axis of the barrel was as stated below:

$$\sigma = \frac{P_{max}R_1}{2t} \tag{A4}$$

where, P is the internal pressure in the cylinder, R_1 is the inner radius of cylinder; and t is the thickness of the cylinder. Given that P_{max} is 16.0 MPa, r is 30 mm, σ is $56 \times 10^6 \text{ N/m}^2$, so that the thickness, t is 4.29 mm. Therefore, the barrel thickness of 4.5 mm was used.

Determination of forces acting on the auger shaft

From the experimental result, the maximum pressure required to express the leaf juice from the leaf mash is 6.09 MPa. Using a method described by Bernard *et al.* (1999) for determining the factor of safety, such as the quality of materials used, control over load applied to parts, accuracy of experimental data, danger to end users and economic impart. A factor of safety of 2.63 was used. Hence, the pressure used as the maximum pressure for this design was 16.0 MPa.

The curved surface area of the pressing zone, A_{CS}

$$A_{CS} = \frac{\pi D_2 L_k}{2} \tag{A5}$$

where, D_2 is the barrel diameter at discharge, 60 mm and L_k is the length of the kink, 40 mm.

Therefore $A_{CS} = 0.00377 \text{ m}^2$

The cross-sectional area of the pressing zone (the discharge end), A_c

$$A_c = \frac{\pi(D_2^2 - D^2)}{4} \tag{A6}$$

where, D_2 is the barrel diameter at discharge, 60 mm and D is the kink diameter, 52 mm.

Therefore $A_c = 0.000704 \text{ m}^2$

$$F_c = P_{max} \times A_c \quad (A7)$$

$$= 11.26 \text{ kN}$$

The static coefficient of friction, μ is calculated as thus:

$$\mu = \tan \theta$$

where θ , is the angle of inclination at which the leaf mash just begins to move on the inclined plane.

Then, μ was calculated as 1.12 using stainless steel as the surface in contact.

Now, for a conservative design based on the maximum pressure P_{max} of 16.0 MPa, the coefficient of friction μ of 1.12, the cross-sectional area of the pressing zone A_c of 0.000704 m², the curved surface area A_{cs} of 0.377 m², the compression force F_c of 11.26 kN. Therefore, the tangential force F_t was 78.83 kN.

Determination of auger shaft diameter

The shaft on which the screw material was wound was designed based on the following assumptions:

(i) The solid shaft was made from austenitic stainless steel (0.3% C, 18% Cr, and 8% Ni) with a yield strength of 280 MN/m². The density, ρ_s was 8030 kg/m³; the modulus of elasticity, G was 206 GN/m²; the modulus of rigidity, R was 73 GN/m²; the maximum permissible angle of twist, β is 1° per 300 mm length, (Hall *et al.*, 1961) i.e. 2.0° for the 0.6 m length, thus, the length, L was 0.5 m from bearing to bearing. The design of the shaft was based on the maximum shear theory (Spotts, 1971).

$$\tau_{max} = \frac{0.5\tau_{typ}}{FS} \quad (A8)$$

where, τ_{max} is the maximum shear stress in N/m², τ_{typ} is the yield strength in N/m² and FS is the factor of safety.

The factor of safety was calculated using a method described by Bernard *et al.* (1999). The factors considered include: the quality of

materials used, control over load applied to parts, accuracy of experimental data, danger to end users and economic impact. A factor of safety of 2.5 was used.

Then,

$$\tau_{max} = 56 \times 10^6 \text{ N/m}^2$$

But

$$\tau_{max} = \frac{16T}{\pi d^3} \quad (A9)$$

Where, d is the required shaft diameter in mm, T is the Torque in Nm.

$$T = \frac{9550 \times P_R (\text{kW})}{N} \quad (A10)$$

P_R is power required, kW

$$\text{Given that speed, } N = 60 \text{ rpm, } P = 1.0 \text{ kW}$$

$$= 159.17 \text{ Nm}$$

Then $d = 25 \text{ mm}$;

Therefore, r is 12.5 mm.

As a design check, the torsion of shafts equation for a solid circular shaft is:

$$\frac{T}{J} = \frac{\tau}{r} = \frac{G\beta}{L} \quad (A11)$$

from which

$$\tau = \frac{rG\beta}{L} \quad (A12)$$

Given that r is 12.5 mm, then τ is 61.782 x 10⁸ MN/m².

As 56 x 10⁶ MN/m² is less than 61.782 x 10⁸ MN/m², the shaft radius of 12.5 mm is safe for a twist angle of 2° on a length of 0.5 m, that is, the shaft of diameter 25 mm can withstand a stress of 61.782 x 10⁸ MN/m² which is more than the calculated stress of 56 x 10⁶ MN/m².

For the applied torque

$$T = \frac{G\beta J}{L} = 189.54 \text{ Nm}$$

i.e. a shaft of radius 12.5 mm will also withstand a torque of 189.54 Nm which is higher than the torque of 159.16 Nm calculated, hence it is safe to use the 25.0 mm diameter shaft. The shaft will not fail due to shear stress, torque or torsion.

Shaft Component Diagrams

☐ Material

Material		Stainless steel
Modulus of Elasticity	E	206000 MPa
Modulus of Rigidity	G	80000 MPa
Density	ρ	7860 kg/m ³
Length	L	681.000 mm
Mass	Mass	2.984 kg
Results		
Ideal diameter	d	10.19mm
Maximum bending moment	BM _{max}	5.19 Nm

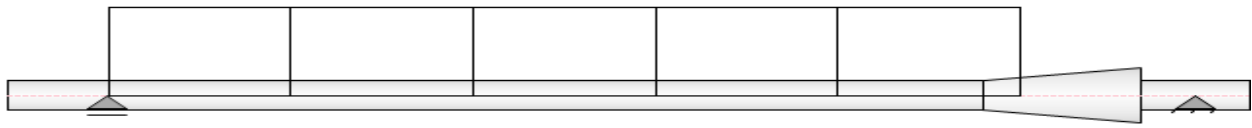

Shear Force, YZ Plane

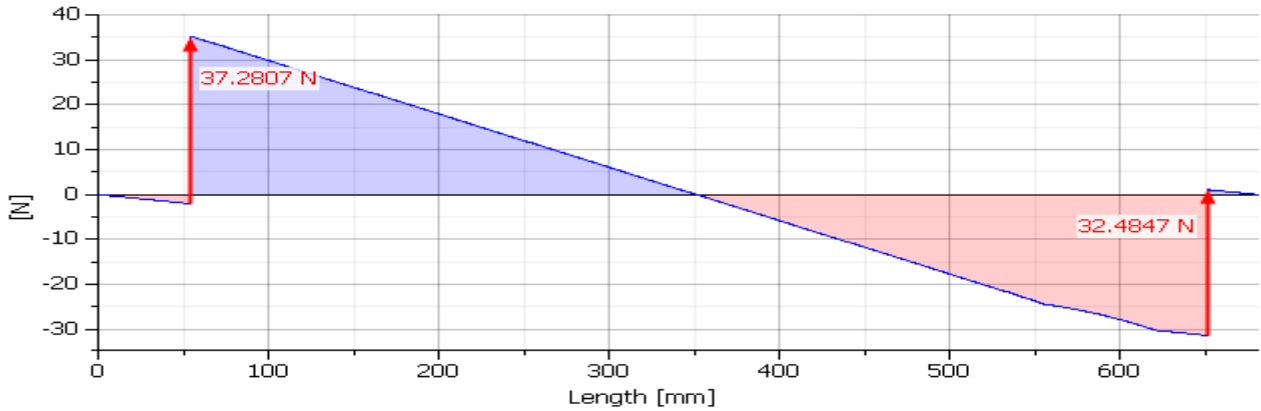

Bending Moment, YZ Plane

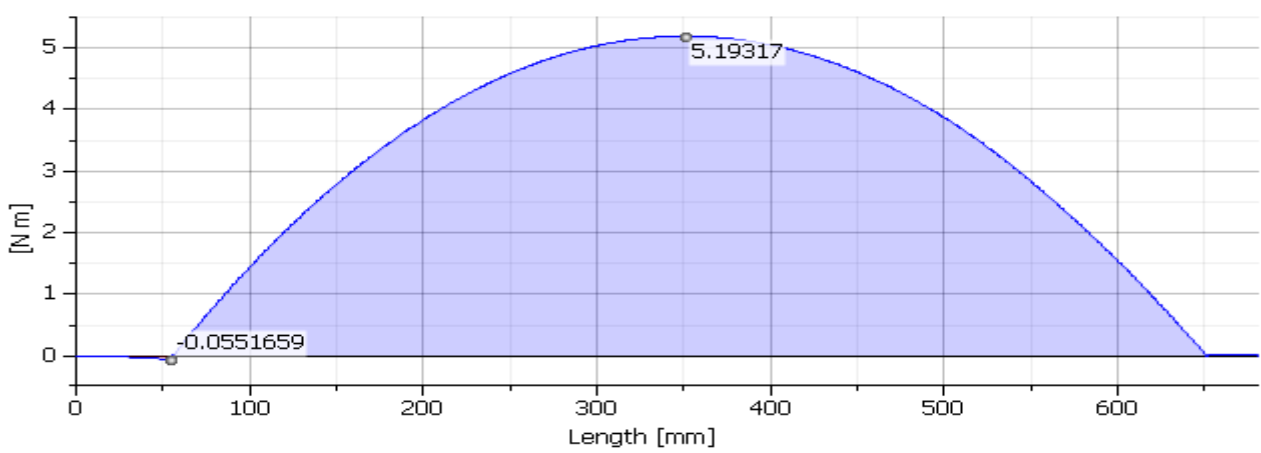

Ideal Diameter

